

Root respiration in citrus acclimates to temperature and slows during drought

D. R. BRYLA, T. J. BOUMA & D. M. EISSENSTAT

Department of Horticulture, The Pennsylvania State University, University Park, PA 16802, USA

ABSTRACT

Citrus seedlings were grown in soil columns in which the root system was hydraulically separated into two equal layers; this enabled us to maintain roots in the upper layer without water for 110 d. The columns were placed into waterbaths modified so that soil temperatures in the top layer could be maintained at 25 °C or at 35 °C, while temperature in the bottom layer was maintained at 25 °C. We hypothesized that, if citrus plants were grown in dry soil for an extended period, root mortality would increase if the cost of maintaining the roots was increased by elevating the soil temperature. However, during the drought period we did not observe any root mortality, even at the higher soil temperature. Moreover, we did not find that root respiration was increased by prolonged exposure to drought and higher soil temperature. We did find that root respiration rates slowed in dry soil. Furthermore, when the soil columns were switched from one temperature treatment to another, root respiration rates in wet soil rapidly increased when moved to a higher temperature or rapidly decreased when moved to a lower temperature. But after only 4 d, respiration rates returned to their original level; root respiration in dry soil was not affected by either short- or long-term shifts in soil temperature. Root respiration in citrus appears to acclimate rapidly to changes in soil temperature.

Key-words: *Citrus volkameriana*; biomass allocation; drought; root respiration; root turnover; soil temperature; Volkamer lemon.

INTRODUCTION

Eissenstat & Yanai (1997) observed in a recent review that root lifespan varies greatly from days to years, depending on the plant species. For example, the median lifespan of the roots produced over the whole year in deciduous trees has been shown to vary from 20 to 340 d (Hendrick & Pregitzer 1992, 1993; Hooker *et al.* 1995). Thorough root demographic studies also reveal that root lifespan varies within a species, as well as over the course of the growing season. In citrus species, the median root lifespan of trees growing in the field is 16–348 d, depending on the time of root production and the rootstock genotype (Eissenstat & Yanai 1997).

Drought is often suggested as the primary cause of root death in many field systems (Deans 1979; Persson 1979; Ferrier & Alexander 1991; Huang & Nobel 1992). Drought conditions near the soil surface are common, even though water is usually sufficient to sustain water uptake deeper in the soil profile. It is during extended drought periods that surface roots may be readily shed. Consequently, whole-plant maintenance costs may be reduced by shedding roots when soil conditions are not favourable for water or nutrient uptake. In tall grass prairie sites dominated by big bluestem (*Andropogon gerardii*), Hayes & Seastedt (1987) examined root turnover during a 58 d drought with only 28 mm of precipitation. They found rapid root mortality, especially in the top 10 cm, within the first 2 weeks of drought. Klepper *et al.* (1973) and Smucker, Nunez-Barrios & Ritchie (1991) also found considerable root death in surface roots after only a few weeks of drought in cotton and corn, respectively.

An alternative strategy to shedding roots during unfavourable soil conditions is to maintain those roots (Van Vuuren *et al.* 1997), later reducing the need to construct new roots when more favourable soil conditions prevail. Fine roots have been shown to survive and even grow in soil water potentials well below -1.5 MPa (Teskey, Grier & Hinckley 1985). When different citrus genotypes were exposed to localized drought, little root mortality occurred, even after more than 60 d of drought (Kosola & Eissenstat 1994). Because roots in dry soil often have limited growth and nutrient uptake during drought, the primary respiratory costs in roots during drought are usually strictly incurred by maintenance of the root tissue. Therefore, costs of maintaining roots in droughted soil can be reduced by slowing down root respiration. Espeleta & Eissenstat (1997) found in field-grown grapefruit trees that localized drought caused root growth and respiration rates gradually to decline as soil water was depleted.

Recent research suggests that soil temperatures may also increase root turnover. Hendrick & Pregitzer (1993) found that sugar-maple stands at a warmer southern site in Michigan had substantially shorter lifespans than those on a northern site. Because root respiration increases as a function of soil temperature (Edwards 1991; Lambers, Atkin & Scheurwater 1995; T. J. Bouma *et al.* 1997), the cost of maintaining roots in warmer soil should also increase. Therefore, we predict that fine roots that incur large respiratory costs (for example, when soil temperature is high) are shed sooner than roots with smaller respiratory

costs (for example, when soil temperature is low), particularly when the roots are exposed to stress such as localized drought. The rate of root respiration at any given measuring temperature, however, may also depend on the degree to which the roots have acclimated to the growth temperature. Acclimation of respiration to temperature results in homeostasis of respiration, such that warm-acclimated and cold-acclimated plants display similar rates of respiration when measured at their respective growth temperatures (Körner & Larcher 1988). Acclimation of root respiration to soil temperature occurs in *Plantago lanceolata* (Smakman & Hofstra 1982) and *Zostera marina* (Zimmerman *et al.* 1989), but not in *Picea glauca* (Weger & Guy 1991), *Picea engelmannii* (Sowell & Spomer 1986), or *Abies lasiocarpa* (Sowell & Spomer 1986).

The main objective of the present study was to determine if root mortality increased during drought when roots were exposed to higher soil temperatures. We also examined the effect of soil temperature on the rates of root respiration, to understand how root respiration might relate to root lifespan. Citrus is commonly grown in sandy soils that dry rapidly, and in warm locations where surface temperatures often vary widely over the course of the day. These conditions create a harsh growing environment for young roots. Volkamer lemon (*Citrus volkameriana*) was chosen for this study, and grown at two different root temperatures in soil columns. A wax layer that hydraulically separated the surface roots from deeper roots in each column enabled us to expose the surface roots to localized drought for an extended period.

MATERIALS AND METHODS

Split-soil-column system

Split-soil columns were designed to separate the vertical distribution of roots into equal upper and lower compartments (Fig. 1). The columns were made by connecting two 30 cm lengths of polyvinyl chloride (PVC) pipe (10 cm diameter) with a coupler, cementing a flange to the top end and a cap to the bottom end, and sealing all joints with silicon caulk. To monitor root turnover non-destructively, clear butyrate tubes (12 mm inside diameter) were inserted horizontally into holes predrilled at 5, 15, 25, 35, 45, and 55 cm depths; the tubes allowed visual access using an 8 mm borescope (Olympus America Inc., Lake Success, NY, USA) attached to a video camera (Bartz Technology, Santa Barbara, CA, USA). The position of any roots growing adjacent to the tubes could later be determined from lines etched in 1 cm increments along the length of each tube. Outside the columns, these tubes were covered with black tape and the holes were stoppered to prevent light penetration. An irrigation port was installed at the top of the lower soil compartment and a drainage port at the base of the upper and lower compartments. The upper and lower compartments were separated hydraulically by a 5-mm-thick wax layer that was soft enough to enable roots to penetrate the lower compartment. The wax layer was made by

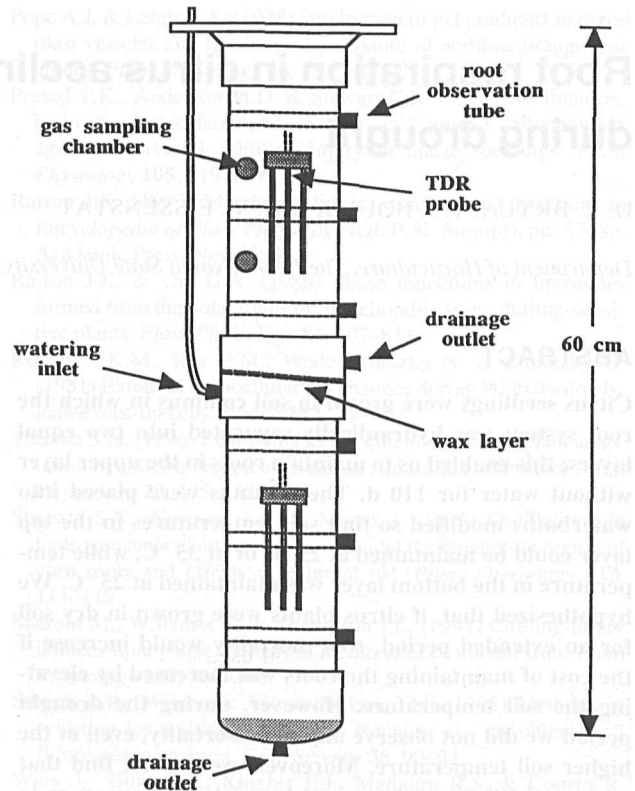

Figure 1. Schematic diagram of the split-soil-column system. A wax layer at a depth of 30 cm hydraulically separated the column into upper and lower root compartments. Root observation tubes at 10 cm intervals permitted visual access with a borescope for non-destructive monitoring of root turnover. Soil water content was monitored by time domain reflectometry (TDR) probes placed in the centre of each soil compartment. Coaxial cable attached to each probe extended to the soil surface and could be connected to a TDR cable tester. Gas-sampling chambers were installed in the upper soil compartment at depths of 10 and 20 cm. Thin (1-mm-diameter), flexible tubing attached to each chamber extended to the soil surface so that gas samples could be extracted with a syringe. The tubing was plugged between samplings to prevent air in the chambers from mixing with ambient air.

filling the pots halfway with soil and pouring a melted mixture of one volume of hard paraffin wax and nine volumes of petroleum jelly, cooled just above the freezing point (around 50 °C), on to the soil surface. Plants (see below) were then transplanted into the upper compartment. When roots grew through the wax layer (that is, when plants no longer wilted when the surface soil dried), this system allowed us to expose the surface roots to extended periods of drought by withholding water from the upper compartment and watering only the lower compartment. Changes in volumetric soil water content were monitored using time domain reflectometry (TDR; see Topp 1993); TDR probes (unbalanced design; stainless-steel rods 11 cm long and 1.6 mm in diameter) were buried vertically in the centre of the upper and lower compartments of each soil column during transplanting. Soil temperature was measured continuously with copper-constantan thermocouples buried at

depths of 2, 5, 10, 25 and 50 cm and attached to a datalogger (model CR10, Campbell Scientific Inc., Logan, UT, USA). Gas-sampling chambers were buried at depths of 10 and 20 cm during transplanting. These chambers were made from plastic syringes by cutting the barrel 15 mm back from the tip and gluing screen (30 μm openings) to the cut side of the tip end; flexible tubing was attached to the tip and protruded from the soil surface. Air samples were later extracted from the soil chambers using a 3 cm^3 syringe and CO_2 concentrations in the air were analysed using gas chromatography (model 5840A, Hewlett-Packard, Palo Alto, CA, USA). Gas-sampling chambers were also buried in the lower soil compartments at depths of 40 and 50 cm, but could not be analysed because they filled with water after irrigation.

Growth conditions

In March 1995, seeds of Volkamer lemon (*Citrus volkameriana* Tan. & Pasq.) were germinated, and after 7 months, uniformly sized seedlings were selected and transplanted into the split-soil columns. The soil used in the study was an autoclaved (121 °C) Candler fine sandy soil, collected from the Citrus Research and Education Centre in Lake Alfred, FL, USA. Each soil column was filled with ≈ 4 kg of air-dry soil. Plants were grown in a heated glasshouse in natural light supplemented by 200 W sodium-halide lamps (14 h photoperiod). Plants were watered to field (container) capacity as needed and fertilized weekly using a modified Hoagland's solution (5 mol m^{-3} KNO_3 , 5 mol m^{-3} $\text{Ca}(\text{NO}_3)_2$, 5 mol m^{-3} KH_2PO_4 , 2 mol m^{-3} MgSO_4 , 1 mol m^{-3} Fe as FeEDTA, and micronutrients).

Treatments

When the plants were well established and roots were visible through the observation tubes in the lower compartment of each soil column (2 months after transplanting), the columns were placed in two large waterbaths used to control soil temperature. One waterbath was set at 25 °C and completely filled with water. A second waterbath, also set at 25 °C, was filled to a level that covered only the lower compartment of each soil column; the upper 30 cm was heated to 35 °C with a thermostatically controlled radiator system. The radiator system was constructed from aluminium tubing welded to 0.5-mm-thick aluminium sheets and water was circulated through the tubing from a tank heated by a copper element. This enabled us to compare the effects of elevated soil temperature on root respiration and turnover at the surface (upper compartment) while deeper roots (lower compartment) were exposed to similar temperatures. Heating only the upper soil compartment is more consistent with field conditions where soil temperatures are usually higher at the surface during the day because of heating by the sun. Twenty plants were randomly assigned to each waterbath.

To examine the effects of drought on root respiration and turnover, after a 2 week acclimation period, water was

withheld from the upper compartment of 10 plants in each waterbath, while the remaining plants continued to receive water in both the upper and lower compartments. Overall, there were two temperature blocks (25 °C/25 °C and 35 °C/25 °C) and each block had two irrigation treatments (watered and droughted) with 10 replicates each; temperature could not be considered as a treatment because we had only two waterbaths available to control soil temperature in the study. The drought treatments were maintained for a period of 110 d.

Measurements

Soil moisture and temperature

To determine the diurnal patterns of soil moisture and temperature at various depths in each treatment, readings of water content (2 h intervals; five plants per treatment) and temperature (10 min intervals; two plants per treatment) were collected every 20–30 d during the experiment, beginning after the drought treatment was started.

Plant water status and growth

To determine the water status of the plants during the experiment, stem water potentials were estimated by measuring the water potentials of leaves that had been enclosed overnight in a black plastic bag covered with aluminium foil (Begg & Turner 1970). Water potentials were measured on recently matured leaves with a pressure chamber (Soil Moisture Equipment Corp., Santa Barbara, CA, USA). Preliminary measurements indicated that daily changes in stem water potential were less variable than the leaf water potential (data not shown) and are probably a more sensitive indicator of water stress (McCutchan & Shackel 1992). Five plants from each treatment were randomly chosen and measurements were made at 24, 45 and 85 d after withholding water.

Stem height and number of fully expanded leaves of each plant were measured every 30 d during the experiment. These values were related to total leaf area of the plant after the plants were harvested, by measuring the actual areas of every leaf at each height with an image analysis system (Delta-T, Dynamax Inc., Houston, TX, USA).

Roots visible along the boroscope tubes were videotaped every 2 weeks beginning at the start of the drought treatment. Changes in the status of the roots in each treatment were monitored by directly comparing consecutive videotapes. Two cohorts of roots (2–10 roots per tube), produced before the start of the drought treatment or in the first 4 week period after drought was started, were followed in both droughted and well watered plants until the end of the experiment. Roots were considered dead if they disappeared from the tubes or showed symptoms typical of decay (for example, brown-black discoloration). When plants were harvested at the end of the experiment, several root pieces were collected from each treatment at various

depths in the upper and lower soil compartments. Viability of the roots was tested by incubating them in a 2,3,5-triphenyl tetrazolium chloride (TTC)–phosphate buffer solution with 0.05% (v/v) Triton x-100 wetting agent at 30 °C for 15 h (Steponkus & Lanphear 1967). Living plant tissue enzymatically reduces tetrazolium salt to insoluble, red formazan (Smith 1951). After incubation, stained roots were examined under a microscope at 40 \times , and were considered metabolically active when individual cells stained pink or red. Test roots killed by desiccation or freezing showed no coloration after incubation.

Root-soil respiration

After water was withheld from the droughted treatments, combined root and soil respiration rates were determined every 14–28 d. Carbon dioxide fluxes were measured at the soil surface of the soil columns with a 0.75 dm³ cylindrical PVC chamber connected to a portable gas-exchange system (LI-6200, Li-Cor Inc., Lincoln, NB, USA). The chamber was built according to the basic design of a Li-Cor LI-6000-09 soil respiration chamber, but used a split lid sealed with a foam gasket and flexible sealant (Terostat) around the stem of the plant during the measurement. To minimize disturbance of the soil atmosphere, air entering the chamber was passed through an aluminium manifold suspended above the soil surface. Before each measurement CO₂ concentrations inside the chamber were reduced to about 20 $\mu\text{mol mol}^{-1}$ below ambient. Each measurement lasted \approx 3 min. Root-soil respiration rates were corrected for stem respiration (measured on a subsample of plants by covering the bottom of the respiration chamber) and expressed per unit of soil surface area. On the same day that root-soil respiration rates were determined, soil gas samples were collected from five soil columns in each treatment and CO₂ concentration was determined by gas chromatography. The level of CO₂ measured in the soil atmosphere allowed us to make direct comparisons between CO₂ levels in the soil and measured rates of CO₂ evolution from the soil. Previous work on Volkamer lemon by Bouma *et al.* (1997) demonstrated that soil CO₂ levels correlated well with rates of root respiration.

An open-circuit gas exchange system was used to ascertain diurnal relationships of root-soil respiration twice during the study. Plastic lids (6-mm-thick sheet) were attached to the top of three soil columns from each treatment and sealed around the base of the plant stems with a flexible sealant (Terostat), forming a 100 cm³ headspace. Rates of respiration were determined by measuring CO₂ efflux from the headspace using an automated gas-exchange system with a Li-Cor model LI-6252 infrared gas analyser (refer to Bouma *et al.* 1997, for technical details). The system automatically rotated among the 12 soil columns at a 4 min interval giving a reading for each object every 48 min. The CO₂ concentration of the incoming air to each column was regulated by mixing CO₂-free air with 0.1 mol CO₂ mol⁻¹ air using two mass flow controllers. The flow to each column was regulated by a needle valve, and measured with

a mass flow meter. The flow into the infrared gas analyser was kept at 300 cm³ min⁻¹, and was independent of the flow through the column head space (\approx 600 cm³ min⁻¹). The first set of diurnal measurements was taken between 51 and 53 d after withholding water. A second set of diurnal measurements was taken between 105 and 110 days, but after 106 d, the soil columns from the 35 °C/25 °C waterbath were moved to the 25 °C/25 °C waterbath and vice versa. This was done to determine the degree of acclimation to soil temperature that occurred in the respiration rates. Data collected during the first 2–3 h after air was passed over the soil column headspace, and after watering, were discarded until CO₂ efflux attained new equilibrium (see Bouma *et al.* 1997). Data were calculated as respiration rates per unit dry weight of the fine roots of the upper soil compartment (nmol CO₂ g⁻¹ s⁻¹). For the second measurement period, root dry weights were determined at final harvest (see below), and for the first measurement period, dry weights were estimated from initial and final harvests and adjusted for growth (root growth rate during the measurement period was assumed constant).

Dry weights and starch analysis

Eight replicates of well watered control plants were harvested before drought treatments were started, to provide an initial measure of shoot and root growth. After the open-system gas exchange measurements were completed, the remaining plants were harvested. Fibrous roots, tap roots, stems and leaves were oven-dried at 60 °C for at least 48 h and weighed. The dried root tissue samples were later ground and two subsamples (5 mg) were suspended in 0.5 cm³ of water, boiled for 10 min, and soluble (amylose) and insoluble (amylopectin) starch were digested using α -amylase and amyloglucosidase, respectively (Haissig & Dickson 1979), or left undigested. Free sugars from digested and undigested samples were then determined colorimetrically (Somogyi 1951).

RESULTS

Soil and plant water status

At the time that the split-soil columns were placed in the waterbaths and the treatments were imposed, the plants were rapidly depleting water from the upper soil compartments; if watering was withheld, within 36 h the percentage of soil water available to the roots in the droughted compartments was less than 1.5% (Fig. 2). Soil water content remained low in the upper compartment of the droughted treatments and was measured gravimetrically at 0.7% (\pm 0.1% SE) when the plants were harvested at 110 d. Roots in the lower compartments, however, took several weeks before appreciable amounts of water were absorbed on a daily basis, whether the upper compartment was droughted or not (an example at 51–53 d after watering was withheld is shown in Fig. 3a). Soil temperature had little effect on daily water uptake, as indicated by nearly

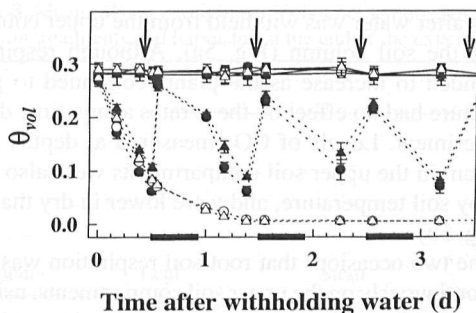

Figure 2. Initial changes in the volumetric soil water content (θ_{vol}) over time (± 1 SE) for Volkamer lemon grown in split-soil columns as shown in Fig. 1. Soil temperatures were controlled at 35 °C in the upper compartment and 25 °C in the lower compartment (\bullet, \circ), or at 25 °C in both the upper and lower compartments ($\blacktriangle, \triangle$). The upper compartments of the soil columns for both temperature treatments were well watered (\bullet, \blacktriangle) or droughted (\circ, \triangle). Dashed lines represent the upper compartments and solid lines the lower compartments. Arrows indicate time of watering.

identical patterns of soil water content in the two temperature treatments. Whether the upper compartments were maintained at 25 °C or at 35 °C, changes in soil water values were similar.

Daily fluctuations in soil temperatures in both temperature treatments were minimal over the course of the experiment, and the mean temperatures \pm the range consistently remained either at 35 ± 2 °C or 25 ± 3 °C in the upper soil compartments and 25 ± 1 °C in the lower soil compartments (Fig. 3b).

Midday stem water potentials estimated from measurements made on recently mature leaves at 24 d after water was withheld were three times lower than those of plants watered daily (Table 1), which indicates that these plants were initially water stressed. Consequently, leaf area development was limited in the droughted plants until ≈ 45 d after watering was withheld (Fig. 4), and stem water potentials were similar during the droughted and watered treatments (Table 1).

Root turnover and total biomass production

Little apparent root death was observed in the upper soil compartment in any treatment (Table 2). Vital staining of harvested roots revealed almost no dead tissue ($> 99\%$ of the cells in the roots examined stained red or pink), which indicates that observed roots were alive.

While soil temperature had little effect on the amount of biomass produced above ground, withholding water in the upper soil compartments significantly reduced leaf and stem dry mass (Table 3). In contrast, below ground, the total dry mass of fine roots (lower and upper compartments) was similar in plants that were well watered and plants exposed to drought. The distribution of roots between the compartments, however, was markedly affected by the watering treatment because plants growing

in soil columns that were dry at the surface tended to allocate a much greater proportion of their roots to deeper soil depths (Table 3). Fine root dry weights increased only 20–57% in the droughted upper soil compartments after water was withheld, whereas the dry weight of fine roots growing in well watered soil increased by 135–154% over the same period (Table 3). Soil temperature also had little effect on the dry weight of the fine roots, but had a major impact on the amount of dry mass allocated to the tap roots, particularly when the soil was dry (Table 3).

Root starch

Although root starch and sugar concentrations were mostly similar between the two temperature treatments (except

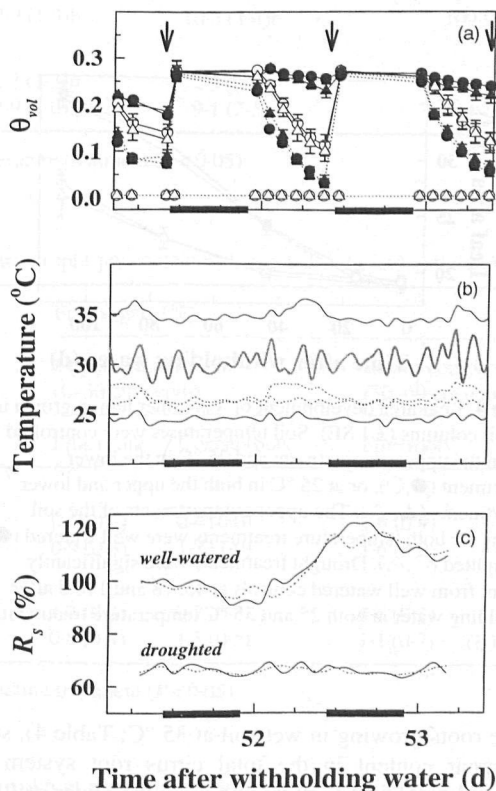

Figure 3. Diurnal fluctuations in (a) volumetric soil water content (θ_{vol}) (± 1 SE), (b) soil temperature, and (c) root-soil respiration rates (R_s) measured on Volkamer lemon grown in split-soil columns as shown in Fig. 1. For θ_{vol} , symbols are the same as in Fig. 2 and the time of watering is represented by arrows. Soil temperatures were controlled at 35 °C in the upper compartment and 25 °C in the lower compartment (solid lines), or at 25 °C in the upper and lower compartments (dashed lines). Ambient air temperature in (b) is represented by the heavy shaded line. Measurements of R_s were made on the upper soil compartments using an open-circuit gas exchange system and data are expressed as a relative percentage of the respiration rate value measured initially at 25 °C in well watered soil. For the sake of clarity, standard errors are not shown for soil temperature or R_s , but soil temperature SE values were 0–0.8 and 0–1.1 °C in wet and dry soil, respectively ($n = 3$); R_s SE values were 0.3–9.1 and 0.1–2.6% in wet and dry soil, respectively ($n = 3$).

Table 1. Mean (SE) stem water potentials at midday for Volkamer lemon saplings grown in split-pot containers

Treatments	Stem water potentials (MPa)		
	Days after withholding water		
	24	45	85
35°C/25°C			
Watered	-0.73 (0.10) ^b ¹	-0.75 (0.10)	-0.72 (0.07)
Droughted	-1.80 (0.09) ^a	-0.79 (0.10)	-0.78 (0.06)
25°C/25°C			
Watered	-0.63 (0.01) ^q	-0.71 (0.10)	-0.74 (0.07)
Droughted	-1.69 (0.06) ^p	-0.76 (0.05)	-0.79 (0.04)

¹Values with different letters are significantly different for that irrigation/temperature treatment ($P < 0.05$).

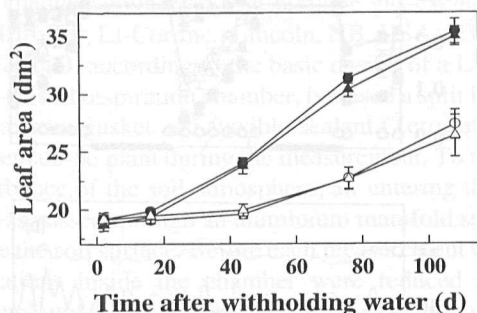

Figure 4. Leaf area development of Volkamer lemon grown in split-soil columns (± 1 SE). Soil temperatures were controlled at 35 °C in the upper compartment and 25 °C in the lower compartment (\bullet, \circ), or at 25 °C in both the upper and lower compartments ($\blacktriangle, \triangle$). The upper compartments of the soil columns for both temperature treatments were well watered (\bullet, \blacktriangle) or droughted (\circ, \triangle). Drought treatments were significantly different from well watered controls at 45, 78 and 110 d after withholding water at both 25 and 35 °C temperature treatments ($P \leq 0.05$).

coarse roots growing in wet soil at 35 °C; Table 4), starch and sugar content in the total citrus root system was reduced by 45% when temperature in the upper soil compartment was elevated from 25 to 35 °C. This primarily occurred because there was less root production at the higher soil temperature (Table 3). Unlike soil temperature, however, drought directly affected the concentration of starch measured in the fine roots. Fine roots growing in wet soil accumulated significantly less starch per unit of root tissue than roots located in dry soil (Table 4), but because more fine roots were produced when the upper soil compartment was irrigated (Table 3), total fine-root starch content was similar between the irrigation treatments.

Root-soil respiration

Instantaneous root-soil respiration rates measured in the upper soil compartment dropped significantly within

2 weeks after water was withheld from the upper compartment of the soil column (Fig. 5a). Although respiration rates tended to increase as the plants continued to grow, temperature had no effect on these rates at any time during the experiment. Levels of CO₂ measured at depths of 10 and 20 cm in the upper soil compartments were also unaffected by soil temperature, and were lower in dry than wet soil (Fig. 5b).

On the two occasions that root-soil respiration was measured continuously on the upper soil compartments, using an open-circuit gas exchange system, variation in respiration rates did not show any diel trend, but remained relatively constant over a 24 h period (Figs 3c & 6). Like measurements with the closed system, continuous measurements with the open system showed that respiration rates were not only lower in droughted than watered treatments, but were also similar at the two different soil temperatures. Therefore, to determine if the plants simply acclimated to soil temperature, plants growing in soil columns controlled at 35 °C in the upper compartment and 25 °C in the lower compartment were switched with plants in the waterbaths that controlled the soil temperature at 25 °C in both the upper and lower compartments. When we did this, the well watered plants that were moved from the higher to lower temperature treatment showed an immediate decline in the root-soil respiration rate (Fig. 6). In contrast, when well watered plants were moved from the lower to higher temperature treatment, root-soil respiration rapidly increased. After only 4 d, however, respiration rates at the different soil temperatures seemed once again to converge (Fig. 6). Furthermore, increasing or decreasing soil temperature had no effect on root respiration in dry soil (Fig. 6).

DISCUSSION

In this study we show that root respiration in citrus rapidly acclimates to soil temperature. Specific rates of CO₂ efflux

Table 2. Percentage root mortality over a 110 d period of Volkamer lemon roots grown in the upper compartment of the split soil system shown in Fig. 1. Biweekly observations were made non-destructively at various depths using a boroscope and observation tubes. Soil temperatures were controlled either at 35 °C in the upper compartment and 25 °C in the lower compartment or at 25 °C in both the upper and lower compartments. The upper compartments for both temperature treatments were either well watered or droughted (cohorts were combined and the number of roots observed are in parentheses). There were no significant differences in mortality among treatments

Depth (cm)	Mortality (%)			
	35°C/25°C		25°C/25°C	
	Watered	Droughted	Watered	Droughted
5	3.4 (48)	2.1 (31)	3.6 (53)	2.0 (33)
15	4.1 (58)	2.3 (39)	3.5 (54)	1.7 (42)
25	2.7 (63)	1.9 (35)	2.9 (66)	2.0 (38)

Table 3. Mean (SE) dry weights of Volkamer lemon grown in split-pot containers harvested prior to the initiation of temperature and irrigation treatments and harvested at the end of the experiment

Treatments	Tissue dry weights (g)					Total
	Leaf	Stem	Roots		Total	
			Upper compartment (0–30 cm depth)	Lower compartment (30–60 cm depth)		
			Fine roots	Coarse roots	Fine roots	
<i>Before drought and temperature treatments were initiated</i>						
	11.8 (0.1)	18.2 (0.4)	5.4 (0.4)	7.7 (0.2)	1.8 (0.2)	45.0 (0.8)
<i>After drought and temperature treatments were initiated</i>						
35°C/25°C						
Watered	29.0 (1.1)b ¹	79.7 (4.7)b	12.7 (0.7)b	15.2 (1.3)a	3.3 (0.5)a	139.9 (8.0)b
Droughted	21.2 (1.1)a	54.0 (1.5)a	6.5 (0.6)a	17.9 (1.3)b	10.3 (1.4)b	109.9 (3.9)a
25°C/25°C						
Watered	27.8 (0.8)q	77.9 (1.8)q	13.7 (1.4)q	22.3 (1.3)p	2.3 (0.5)p	144.0 (3.2)q
Droughted	19.2 (1.5)p	49.5 (3.9)p	8.5 (0.8)p	27.9 (1.0)q	9.1 (2.5)q	114.1 (8.1)p

¹Values with different letters are significantly different for that irrigation/temperature treatment ($P < 0.05$).

Table 4. Mean (SE) root starch and free sugar contents of Volkamer lemon grown in split-pot containers harvested at the end of the experiment

Treatments	Starch (%)		Free sugars (%)				
	Upper compartment (0–30 cm depth)		Lower compartment (30–60 cm depth)		Upper compartment (0–30 cm depth)		Lower compartment (30–60 cm depth)
	Fine roots	Coarse roots	Fine roots	Fine roots	Coarse roots	Fine roots	
35°C/25°C							
Watered	4.2 (0.1)a ¹	4.9 (0.7)a	4.2 (0.7)b	0.5 (0.2)	0.4 (0.0)	1.6 (0.9)	
Droughted	7.4 (0.6)b	6.4 (0.6)b	2.7 (0.8)a	0.9 (0.3)	1.8 (1.0)	1.6 (0.9)	
25°C/25°C							
Watered	4.9 (0.1)p	6.7 (0.6)	3.2 (0.7)	1.2 (0.4)	0.7 (0.3)	0.6 (0.2)	
Droughted	7.7 (0.7)q	6.8 (0.3)	3.3 (0.2)	0.8 (0.4)	1.5 (0.5)	1.1 (0.7)	

¹Values with different letters are significantly different for that irrigation/temperature treatment ($P < 0.05$).

(respiration) from the roots of intact Volkamer lemon plants grown in wet soil responded immediately to changes in soil temperature. When soil temperatures were elevated from 25 to 35 °C, root soil respiration rates suddenly increased, and when they were reduced from 35 to 25 °C, respiration rates immediately decreased (Fig. 6). Root respiration rates often parallel shifts in soil temperature, and it is likely that soil temperature is an important factor controlling daily fluctuations in respiration (Bouma *et al.* 1997). A striking feature of the present study, however, is that over a 4 d period, respiration rates in the wet soil gradually decreased at the warmer soil temperature and increased at the cooler temperature until an intermediate respiration level was reached. This indicates that the roots rapidly acclimated to changes in soil temperature when temperature was held constant. It is common when plants

are grown at a constant temperature, a relatively high light intensity and a long photoperiod, for the rate of root respiration to be rather constant throughout the day (Lambers *et al.* 1995). Buwalda, Fossen, & Lenz (1992) also found that although the respiration rates in roots of intact fruiting *Citrus madurensis* had a Q_{10} (temperature coefficient) of about 2, when soil temperature was controlled at 20 °C, respiration rates measured over a 24 h period did not change significantly.

When the root system was exposed to localized drying, rates of root respiration in Volkamer lemon significantly decreased (Figs 3c & 5). Consequently, root respiration rates in dry soil remained low (about 60% of the well watered plants) and constant even when soil temperatures were increased or decreased (Fig. 6). A gradual decline in root respiration during drought has been reported by others

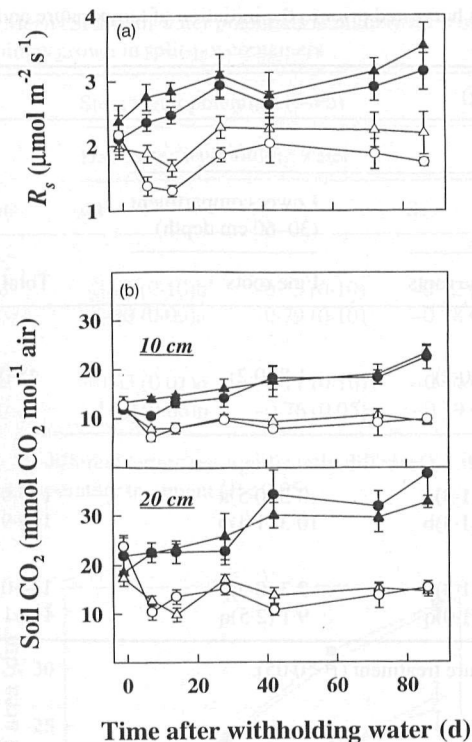

Figure 5. (a) Root-soil respiration rates (R_s) and (b) soil CO_2 concentrations of Volkamer lemon grown in split-soil columns (± 1 SE). Soil temperatures were controlled at 35°C in the upper compartment and 25°C in the lower compartment (\bullet, \circ), or at 25°C in both the upper and lower compartments ($\blacktriangle, \triangle$). The upper compartments of the soil columns for both temperature treatments were well watered (\bullet, \blacktriangle) or droughted (\circ, \triangle). Measurements of R_s were made on the upper soil compartment using a soil respiration chamber connected to a closed-circuit gas-exchange system. Concentrations of CO_2 were measured at 10 and 20 cm depths of the upper soil compartment using gas chromatography. If R_s values are expressed per unit root dry weight (using root dry weight values measured at the start of drought and at the end of the experiment, shown in Table 3), R_s values measured before drought were 7.47 and $7.57 \text{ nmol g}^{-1} \text{ s}^{-1}$ at 35 and 25°C , respectively; R_s values measured at 86 d after withholding water were 5.14 and $4.47 \text{ nmol g}^{-1} \text{ s}^{-1}$ in wet soil and 3.25 and $2.74 \text{ nmol g}^{-1} \text{ s}^{-1}$ in dry soil at 35 and 25°C , respectively. Soil CO_2 concentrations (10 and 20 cm depths) and R_s were significantly lower in dry soil than in wet soil on each date measured after irrigation was withheld at both 25 and 35°C temperature treatments ($P \leq 0.05$).

(Nicolas *et al.* 1985; Sisson 1989) and reduced maintenance costs have been more clearly associated with roots in dry soil. Palta & Nobel (1989) indicate that maintenance respiration of roots of desert succulents in dry soil is only about 13% of that under wet conditions. Lambers *et al.* (1995) suggest that response to drought is likely to be associated with the extent to which growth is affected. Indeed, fine root production was significantly reduced during drought in the present study (Table 3). Espeleta & Eissenstat (1997) also found in roots of juvenile and adult Volkamer lemon that a reduction in root respiration rates directly corresponded to a decline in root production when

isolated portions of the root system were droughted. After 7 weeks of drought, however, they noted that root growth (of seedlings only) resumed and respiration rates began to increase until they returned to the level observed before soil drying.

Over a 110 d period, we observed little root death in Volkamer lemon (less than 5%), even in roots maintained in very dry soil during that time period (Table 2). Although root death during water deficits often occurs in nature (Huck, Hoogenboom & Peterson 1987; Ferrier & Alexander 1991; Huang & Nobel 1992), species that exhibit low root mortality in dry soil are not uncommon (Taylor & Klepper 1973; Meyer *et al.* 1990). We also found that soil temperature did not affect root death in this study. It appears from the results described above that the cost of maintaining roots in citrus may be lessened during adverse soil conditions such as drought by means of decreased root respiration (by reducing root growth or maintenance respiration), and in wet soil by acclimating to changes in soil temperature and consequently reducing the respiratory costs of maintaining roots when soil temperatures are high. The reduction of root respiration that we observed during drought agrees with a previous study on citrus, which found that C allocation below ground was reduced by 80% during drought (Kosola & Eissenstat 1994). Eissenstat & Yanai (1997) suggest that the cost of retaining roots in dry soil should be compared with benefits derived, both during and after drought, to give an indication of optimal lifespan. Thus, optimal lifespan should depend on the likely duration of drought. On the basis of this hypothesis, roots should be shed less readily in species (such as citrus) that are adapted to more mesic conditions

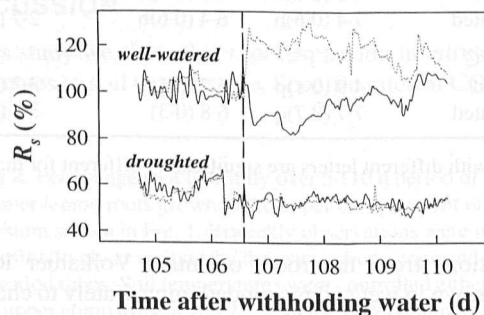

Figure 6. Root-soil respiration rates (R_s) of Volkamer lemon grown in split-soil columns. Soil temperatures were controlled at 35°C in the upper compartment and 25°C in the lower compartment (solid lines), or at 25°C in the upper and lower compartments (dashed lines). The lower compartments were watered regularly while the upper soil compartments were either well-watered or droughted for 110 d and measurements were made on the upper soil compartment using an open-circuit gas-exchange system. Columns from the $35^\circ\text{C}/25^\circ\text{C}$ water bath were moved to the $25^\circ\text{C}/25^\circ\text{C}$ water bath, and vice versa, at 106 d after withholding water (represented by the vertical dashed line). Data are expressed as a relative percentage of the respiration rate value measured initially at 25°C in well watered soil. Standard errors are omitted to enhance clarity, but were 0.2–5.8 and 0–2.4% in wet and dry soil, respectively ($n = 3$).

and construct more expensive roots (g glucose per unit root length), and shed more readily in species that build inexpensive roots and are adapted to long, dry periods (Huang & Nobel 1992). In citrus species, considering the fact that more than 30% of the total fine roots are distributed in the top 10 cm of soil (Castle 1980), where soil temperatures can range from 20 to 40 °C over the course of the day and soil water is readily depleted, it is less surprising that they tend to maintain roots when soil water availability is limited and soil temperature is elevated.

Our data suggest that seasonal variation in soil temperature may have little direct effect on root respiration in citrus over the growing season. Temperature may more indirectly affect root respiration rates by affecting photosynthetic rates or nutrient availability and thus influencing carbon availability. The temperature dependence of N mineralization is widely recognized (Stanford, Friere & Schwaninger 1973; MacDonald, Zak & Pregitzer 1995). Other factors that affect carbon availability for root growth and maintenance, such as fruit setting and pruning (Eissenstat & Duncan 1992), may also affect root respiration rates (Espeleta & Eissenstat 1997). Zogg *et al.* (1996), however, suggested that soil temperature was likely the most important factor controlling temporal patterns in root respiration in a northern hardwood forest. In citrus, root lifespan in the field may be more related to biotic factors than to environmental factors. Kosola, Eissenstat & Graham (1995) found that roots of mature citrus trees had median lifespans of only 16–57 d, and that seasonal and genotypic variation in patterns of citrus fine root mortality were associated with variation in populations of *Phytophthora*—that is, fine root lifespans under field conditions were shorter when populations of *Phytophthora* were high. Root herbivory may also increase root turnover in the field.

When soil temperature was elevated, Volkamer lemon allocated significantly less biomass to supportive root tissue (> 2 mm in diameter) regardless of soil moisture availability (Table 3). Starch concentrations, which represent most of the nonstructural storage carbohydrates in roots, were also lower in coarse roots growing in wet soil at the higher soil temperature (Table 4). These results indicate that respiration rates must have been somewhat faster when soil temperatures were elevated even though differences were undetectable by gas exchange. Indeed, if we assume that all change in plant carbon was accounted for by root respiration, the decrease in root weight observed at the higher soil temperature represents only 0.54 nmol g⁻¹ s⁻¹ in wet soil, and 0.78 nmol g⁻¹ s⁻¹ in dry soil. These values are 1.5 and 3.2% of the measured respiration rates—values well within the error of measurement found for these whole root system respiration measurements.

In summary, Volkamer lemon maintained their fine roots over 100 d, regardless of soil water availability or changes in soil temperature. Maintaining fine roots for extended periods when soil conditions are unfavourable for either nutrient or water uptake can represent a signifi-

cant carbon cost to the plant, particularly at higher soil temperatures. However, it appears that root maintenance costs will be reduced during these conditions in Volkamer lemon because root respiration acclimates to changes in soil temperature and slows during drought. If we are to predict how current changes in our global environment will affect productivity, we need to understand how plants respond below ground to higher soil temperatures and drought.

ACKNOWLEDGMENTS

This research was supported by grants from the National Science Foundation (IBN-9596050) and the United States Department of Agriculture (NRI 94-37107-1024). We thank Cheryl Megivern and Maryann Resendes for technical assistance. Special thanks are due to Ron Hubbard and the Department of Plant, Soils and Biometerology at Utah State University, who developed and provided a computer program that converted the TDR data into values for soil water content.

REFERENCES

- Begg J.E. & Turner N.C. (1970) Water potential gradients in field tobacco. *Plant Physiology* **46**, 343–346.
- Buoma T.J., Nielsen K.L., Eissenstat D.M. & Lynch J.P. (1997) Estimating respiration of roots in soil: Interactions with soil CO₂, soil temperature and soil water content. *Plant and Soil*, in press.
- Buwalda J.G., Fossen M. & Lenz F. (1992) Carbon dioxide efflux from roots of calamodin and apple. *Tree Physiology*, **10**, 391–401.
- Castle W.S. (1980) Fibrous root distribution of 'pineapple' orange trees on rough lemon rootstock at three tree spacings. *Journal of the American Society for Horticultural Science* **105**, 478–480.
- Deans J.D. (1979) Fluctuations of the soil environment and fine root growth in a young Sitka spruce plantation. *Plant and Soil*, **52**, 195–208.
- Edwards N.T. (1991) Root and soil respiration response to ozone in *Pinus taeda* L. seedlings. *New Phytologist* **118**, 315–321.
- Eissenstat D.M. & Duncan L.W. (1992) Root growth and carbohydrate responses in bearing citrus trees following partial canopy removal. *Tree Physiology* **10**, 245–257.
- Eissenstat D.M. & Yanai R.D. (1997) The ecology of root lifespan. In *Advances in Ecological Research*, Vol. 27 (ed. I. Holmes), pp. 1–60. Academic Press, San Diego.
- Espeleta J.F. & Eissenstat D.M. (1997) Response of citrus roots to localized soil drying: a comparison of the fine roots of seedlings with those of adult fruiting trees. *Tree Physiology*, in press.
- Ferrier R.C. & Alexander I.J. (1991) Internal redistribution of N in Sitka spruce seedlings with partly droughted root systems. *Forest Science* **37**, 860–870.
- Haissig B.E. & Dickson R.E. (1979) Starch measurement in plant tissue using enzymatic hydrolysis. *Physiologia Plantarum* **47**, 151–157.
- Hayes D.C. & Seastedt T.R. (1987) Root dynamics of tallgrass prairie in wet and dry years. *Canadian Journal of Botany* **65**, 787–791.
- Hendrick R.L. & Pregitzer K.S. (1992) The demography of fine roots in northern hardwood forest. *Ecology* **73**, 1094–1104.
- Hendrick R.L. & Pregitzer K.S. (1993) Patterns of fine root mortality in two sugar maple forests. *Nature* **361**, 59–61.

- Hooker J.E., Black K.E., Perry R.L. & Atkinson D. (1995) Arbuscular mycorrhizal fungi induced alteration to root longevity of poplar. *Plant and Soil* **172**, 327–329.
- Huang B. & Nobel P.S. (1992) Hydraulic conductivity and anatomy of lateral roots of *Agave deserti* during root growth and drought-induced abscission. *Journal of Experimental Botany* **43**, 1441–1449.
- Huck M.G., Hoogenboom G. & Peterson C.M. (1987) *Soybean Root Senescence Under Drought Stress*. ASA Special Publication no. 50, pp. 109–121.
- Klepper B., Taylor H.M., Huck M.G. & Fiscus E.L. (1973) Water relations and growth of cotton in drying soil. *Agronomy Journal* **65**, 307–310.
- Körner C. & Larcher W. (1988) Plant life in cold environments. In *Plants and Temperature* (eds S. P. Long & F. I. Woodward), pp. 25–57. Symposium of the Society of Experimental Botany, Vol. 42. Applied Science Publishers, Cambridge.
- Kosola K.R. & Eissenstat D.M. (1994) The fate of surface roots of citrus seedlings in dry soil. *Journal of Experimental Botany* **45**, 1639–1645.
- Kosola K.R., Eissenstat D.M. & Graham J.H. (1995) Root demography of mature citrus trees: The influence of *Phytophthora nicotianae*. *Plant and Soil* **171**, 283–288.
- Lambers H., Atkin O.K. & Scheurwater I. (1996) Respiratory patterns in roots in relation to their functioning. In *Plants Roots. The Hidden Half*, 2nd edn (eds Y. Waisel, A. Eshel & U. Kafkaki), pp. 323–362. Marcel Dekker, New York.
- MacDonald N.W., Zak D.R. & Pregitzer K.S. (1995) Temperature effects on kinetics of microbial respiration and net nitrogen and sulfur mineralization. *Journal of the Soil Science Society of America* **59**, 233–240.
- McCutchan H. & Shackel K.A. (1992) Stem-water potential as a sensitive indicator of water stress in prune trees (*Prunus domestica* L. cv. French). *Journal of the American Society for Horticultural Science* **117**, 607–611.
- Meyer W.S., Tan C.S., Barrs H.D. & Smith R.C.G. (1990) Root growth and water uptake by wheat during drying of undisturbed and repacked soil in drainage lysimeters. *Australian Journal of Agricultural Research* **41**, 253–265.
- Nicolas M.E., Lambers H., Simpson R.J. & Dalling M.J. (1985) Effect of drought on metabolism and partitioning of carbon in two varieties of wheat differing in drought tolerance. *Annals of Botany* **55**, 727–742.
- Palta J.A. & Nobel P.S. (1989) Influence of water status, temperature, and root age on daily patterns of root respiration for two cactus species. *Annals of Botany* **63**, 651–662.
- Persson H. (1979) Fine-root production, mortality and decomposition in forest ecosystems. *Vegetation* **41**, 101–109.
- Sisson W.B. (1989) Carbon balance of *Panicum coloratum* during drought and non-drought in the northern Chihuahua desert. *Ecology* **77**, 799–810.
- Smakman H. & Hofstra R. (1982) Energy metabolism of *Plantago lanceolata* as affected by change in root temperature. *Physiologia Plantarum* **56**, 33–37.
- Smith F.E. (1951) Tetrazolium salt. *Science* **113**, 751–754.
- Smucker A.J.M., Nunez-Barrios A. & Ritchie J.R. (1991) Root dynamics in drying soil environments. *Belowground Ecology* **2**, 4–5.
- Somogyi M. (1951) Notes on sugar determination. *Journal of Biological Chemistry* **195**, 19–23.
- Sowell J.B. & Spomer G.G. (1986) Ecotypic variation in root respiration rate among elevational populations of *Abies lasiocarpa* and *Picea engelmannii*. *Oecologia* **68**, 375–379.
- Stanford G., Friere M.H. & Schwaninger D.H. (1973) Temperature coefficients in soil nitrogen mineralization. *Soil Science* **115**, 312–323.
- Steponkus P.L. & Lanphear F.O. (1967) Refinement of the triphenyl tetrazolium chloride method of determining cold injury. *Plant Physiology* **42**, 1423–1426.
- Taylor H.M. & Klepper B. (1973) Rooting density and water extraction patterns of corn (*Zea mays* L.). *Agronomy Journal* **65**, 965–968.
- Teskey R.O., Grier C. & Hinckley T.M. (1985) Relation between root system size and water inflow capacity of *Abies amabilis* growing in a subalpine forest. *Canadian Journal of Forest Research* **15**, 669–672.
- Topp G.C. (1993) Soil water content. In *Soil Sampling and Methods of Analysis* (ed. M. R. Carter), pp. 541–557. Canadian Society of Soil Science, Lewis Publishers.
- Van Vuuren M.M.I., Robinson D., Fitter A.H., Chasalow S.D., Williamson L. & Raven J.A. (1997) Effects of elevated atmospheric CO₂ and soil water availability on root biomass, root length, and N, P and K uptake by wheat. *New Phytologist* **135**, 455–465.
- Weger H.G. & Guy R.D. (1991) Cytochrome and alternate pathway respiration in white spruce (*Picea glauca*) roots. Effects of growth and measurement temperature. *Physiologia Plantarum* **83**, 675–681.
- Zimmerman R.C., Smith R.D. & Alberte R.S. (1989) Thermal acclimation and whole-plant carbon balance in *Zostera marina* L. (eelgrass). *Journal of Experimental Marine Biology and Ecology* **130**, 93–109.
- Zogg G.P., Zak D.R., Burton A.J. & Pregitzer K.S. (1996) Fine root respiration in northern hardwood forests in relation to temperature and nitrogen availability. *Tree Physiology* **16**, 719–725.

Received 14 April 1997; received in revised form 4 August 1997; accepted for publication 6 August 1997

This document is a scanned copy of a printed document. No warranty is given about the accuracy of the copy. Users should refer to the original published version of the material.